



DesignMax	Einbaulautsprecher – DM Serie	Link
	Aufbaulautsprecher – DM Serie inkl. wetterfeste Ausführungen	Link
	Pendellautsprecher – DM Serie inkl. wetterfeste Ausführungen	Link
	Subwoofer – DM Serie	Link
	Zubehör – Einbetoniergehäuse / Wandhalter / Montageelement	Link
FreeSpace	Ein- u. Aufbaulautsprecher / Subwoofer – DS Serie / 360P-II-Serie	Link
	Einbau-Lautsprecher – FS Serie (EN 54-24)	Link
	Aufbau-Lautsprecher – FS-Serie / Pendellautsprecher (EN 54-24)	Link
	Zubehör – Einbetoniergehäuse / Wandhalter / Montageelement / Abhängevorrichtung	Link
	Mischverstärker – IZA-Serie	Link
	Fernbedienungen – CC-1 / CC-2 / CC-3	Link
	Zubehör – IZA-Serie	Link
EdgeMax	Einbau-Lautsprecher mit PhaseGuide® Technologie	Link
Panaray	Modular Säulen-Lautsprecher – aktiv / passiv / wetterfeste Ausführungen	Link
	Subwoofer – MB210	Link
	Zubehör – Panaray	Link
AMM	Multipurpose Lautsprecher – AMM108 / AMM112 / AMM115 inkl. Zubehör	Link
ShowMatch	DeltaQ™ Array Lautsprecher - SM5 / SM10 / SM20 / SM5WG55 / SM20WG12	Link
	Subwoofer - SMS118	Link
	Zubehör – ShowMatch-Serie / Flugrahmen, Kabel, Clustermodule.....	Link
ArenaMatch	Array Lautsprecher – AM10 / AM20 / AM40	Link
	Zubehör – ArenaMatch	Link
	Utility Aufbau-Lautsprecher - AMU105 - 108 - 206 - 208	Link
PowerShare	Endstufen – PowerShare-Serie	Link
	Fernbedienungen – CC-1	Link
PowerSpace	Endstufen – PowerSpace-Serie	Link
	Fernbedienungen – CC-1 / CC-2 / CC-3	Link
Commercial Sound Prozessor	CSP-Serie	Link
	Zubehör – CSP- 428 / 1248	Link
ControlCenter	Fernbedienungen – CC-1(D) / CC-2(D) / CC-3(D) / CC-64 / CC-16	Link
	Zubehör für Fernbedienungen - Netzteil / AP-Rahmen / UP-Boxen	Link
ControlSpace	Audio-DSP - ESP / EX	Link
	Dante Erweiterungen	Link
PowerMatch	Endstufen	Link
	Zubehör	Link
	Fernbedienungen	Link

Ersetzt alle bisherigen Preislisten.

Remplace et annule les précédentes listes de prix.

Artikel mit grau unterlegtem Händlercode sind Neuheiten oder haben eine Preisänderung erfahren.

Articles avec code client gris sont des nouveautés ou ont changé de prix.

Bei Artikeln mit unterstrichenem Händlercode bitte Verfügbarkeit anfragen!



Lautsprecher

DesignMax / Einbau-Lautsprecher		VPE			
	DM2C-LP-W	Full-Range, 2.25", 20W AES @16Ohm, 2.3/4.5/9W@100V, Frequenzbereich 95Hz-18kHz -3dB, max. SPL 103dB, Abstrahlwinkel 180°, Aussen-Ø 198mm, Einbau-Ø 165mm, Einbautiefe 99mm, 1.6Kg, weiss	2	C2	175.-
	DM2C-LP-B	Dito, schwarz	2	C2	175.-
	DM3C-W	2-Weg, 3.25"/0.75", 30W AES @8Ω, 6/12/25W@100V, Frequenzbereich 85Hz-19kHz -3dB, max. SPL 104dB, Abstrahlwinkel 170°, Aussen-Ø 255mm, Einbau-Ø 208mm, Einbautiefe 144mm, 2.7Kg, weiss	2	C2	255.-
	DM3C-B	Dito, schwarz	2	C2	255.-
	DM5C-W	2-Weg, 5.25"/1", 60W AES @8Ω, 6/12/25/50W@100V, Frequenzbereich 73Hz-17kHz -3dB, max. SPL 110dB, Abstrahlwinkel 160°, Aussen-Ø 303mm, Einbau-Ø 250mm, Einbautiefe 192mm, 4.45Kg, weiss	2	C2	345.-
	DM5C-B	Dito, schwarz	2	C2	345.-
	DM6C-W	2-Weg, 6.5"/1.25", 125W AES @8Ω, 5/10/20/40/80W@100V, Frequenzbereich 70Hz-20kHz -3dB, max. SPL 114dB, Abstrahlwinkel 145°, Aussen-Ø 356mm, Einbau-Ø 292mm, Einbautiefe 223mm, 6.5Kg, weiss	2	C2	455.-
	DM6C-B	Dito, schwarz	2	C2	455.-
	DM8C-W	2-Weg, 8"/1", 150W AES @8Ω, 5/10/20/40/80W@100V, Frequenzbereich 60Hz-20kHz -3dB, max. SPL 118dB, Abstrahlwinkel 175°, Aussen-Ø 409mm, Einbau-Ø 349mm, Einbautiefe 240mm, 9.57Kg, weiss		C2	705.-
	DM8C-B	Dito, schwarz		C2	705.-
DesignMax / Aufbau-Lautsprecher					
	DM3SE-W	2-Weg, 3.25"/0.75", 30W AES @8Ω, 6/12/25W@100V, Frequenzbereich 85Hz-20kHz -3dB, max. SPL 105dB, 140° hor. / 140° vert, (H)232mm x (B)154mm x (T)154mm, 2.8Kg, inkl. Halterung, <u>Wetterfest</u> , weiss	2	C2	310.-
	DM3SE-B	Dito, schwarz	2	C2	310.-
	DM5SE-W	2-Weg, 5.25"/1", 60W AES @8Ω, 6/12/25/50W@100V, Frequenzbereich 73Hz-17kHz -3dB, max. SPL 111dB, 135° hor. / 135° vert, (H)286mm x (B)192mm x (T)195mm, 4.8Kg, inkl. Halterung, <u>Wetterfest</u> , weiss	2	C2	435.-
	DM5SE-B	Dito, schwarz	2	C2	435.-
	DM6SE-W	2-Weg, 6.5"/1.25", 125W AES @8Ω, 20/40/80W@100V, Frequenzbereich 70-20kHz -3dB, max. SPL 115dB, 125° hor. / 125° vert, (H)340mm x (B)222mm x (T)227mm, 6.4Kg, inkl. Halterung, <u>Wetterfest</u> , weiss	2	C2	530.-
	DM6SE-B	Dito, schwarz	2	C2	530.-
	DM8S-W	2-Weg, 8"/1", 150W AES @8Ω, 5/10/20/40/80W@100V, Frequenzbereich 60-20kHz -3dB, max. SPL 118dB, 130° hor. / 130° vert, (H)395mm x (B)249mm x (T)353mm, 10.3Kg, inkl. Halterung, weiss		C2	765.-
	DM8S-B	Dito, schwarz		C2	765.-



DesignMax / Pendellautsprecher

	DM3P-W	2-Weg, 3.25"/0.75", 30W AES @8Ω, 6/12/25W@100V, Frequenzbereich 85Hz-20kHz -3dB, max. SPL 105dB, Abstrahlwinkel 130° konisch, Aussen-Ø 207mm, (H)498mm, 2.5Kg, inkl. Montageseil, weiss	2	<u>C2</u>	330.–
	DM3P-B	Dito, schwarz	2	<u>C2</u>	330.–
	DM5P-W	2-Weg, 5.25"/1", 60W AES @8Ω, 6/12/25/50W@100V, Frequenzbereich 80Hz-20kHz -3dB, max. SPL 111dB, Abstrahlwinkel 120° konisch, Aussen-Ø 259mm, (H)286mm, 4.1Kg, inkl. Montageseil, weiss	2	<u>C2</u>	395.–
	DM5P-B	Dito, schwarz	2	<u>C2</u>	395.–
	DM6PE-W	2-Weg, 6.5"/1.25", 125W AES @8Ω, 20/40/80W@100V, Frequenzbereich 75-20kHz -3dB, max. SPL 116dB, Abstrahlwinkel 115° konisch, Aussen-Ø 308mm, (H)356mm, 5.7Kg, inkl. Montageseil, <u>Wetterfest</u> , weiss	2	<u>C2</u>	530.–
	DM6PE-B	Dito, schwarz	2	<u>C2</u>	530.–

DesignMax / Subwoofer

	DM8C-SUB-W	Subwoofer, 8", 180W AES @8Ω, 40/80/150W@100V, Frequenzbereich 45Hz-117Hz -3dB, max. SPL 118dB, Abstrahlwinkel omnidirektional, Aussen-Ø 409mm, Einbau-Ø 349mm, Einbautiefe 240mm, 9.8Kg, weiss		C2	585.–
	DM8C-SUB-B	Dito, schwarz		C2	585.–
	DM10S-SUB-W	Subwoofer, 10", 300W AES @8Ω, 40/80/150W@100V, Frequenzbereich 41Hz-108Hz -3dB, max. SPL 121dB, Abstrahlwinkel omnidirectional, (H)495mm x (B)318mm x (T)318mm, 16.1Kg, inkl. Halterung, weiss		C2	665.–
	DM10S-SUB-B	Dito, schwarz		C2	665.–
	DM10P-SUB-W	Subwoofer, 10", 300W AES @8Ω, 40/80/150W@100V, Frequenzbereich 46Hz-108Hz -3dB, max. SPL 116dB, Abstrahlwinkel omnidirektional, Aussen-Ø 400mm, (H)383mm, 8.9Kg, inkl. Montageseil, weiss		<u>C2</u>	690.–
	DM10P-SUB-B	Dito, schwarz		<u>C2</u>	690.–



FreeSpace FS / Einbau-Lautsprecher			VPE		
	FS2C-W	Full-Range, 2.25", 20W AES @16Ω, 2/4/8/16W @100V, Frequenzbereich 95Hz-16kHz -3dB, max. SPL 104dB, Abstrahlwinkel 150°, Aussen-Ø 182mm, Einbau-Ø 165mm, Einbautiefe 125mm, EN 54-24, 9.57Kg, weiss	2	C2	140.–
	FS2C-B	Dito, schwarz	2	C2	140.–
	FS4CE-W	Full-Range, 4.5", 50W AES @8Ω, 5/10/20/40W @100V, Frequenzbereich 80Hz-16kHz -3dB, max. SPL 110dB, Aussen-Ø 272mm, Einbau-Ø 250mm, Einbautiefe 163mm, EN 54-24, 3.47Kg, <u>Wetterfest</u> , weiss	2	C2	240.–
	FS4CE-B	Dito, schwarz	2	C2	240.–
FreeSpace FS / Aufbau-Lautsprecher					
	FS2SE-W	Full-Range, 2.25", 20W AES @16Ω, 2/4/8/16W @100V, Frequenzbereich 95Hz-16kHz -3dB, max. SPL 105dB, 145° hor. / 140° vert, (H)199mm x (B)113mm x (T)114mm, EN 54-24, 3.47Kg, inkl. Halterung, <u>Wetterfest</u> , weiss	2	C2	190.–
	FS2SE-B	Dito, schwarz	2	C2	190.–
	FS2P-W	Dito, Aussen-Ø 149mm (H)215mm, <u>nicht Wetterfest</u> , inkl. Montageseil, weiss	2	C2	190.–
	FS2P-B	Dito, schwarz	2	C2	190.–
	FS4SE-W	Full-Range, 4.5", 50W AES @8Ω, 5/10/20/40W @100V, Frequenzbereich 80Hz-16kHz -3dB, max. SPL 111dB, 130° hor. / 125° vert, (H)277mm x (B)171mm x (T)174mm, EN 54-24, 3.08Kg, inkl. Halterung, <u>Wetterfest</u> , weiss	2	C2	330.–
	FS4SE-B	Dito, schwarz	2	C2	330.–
DesignMax und FreeSpace FS / Lautsprecher-Zubehör					
	Pan&Tilt Brkt Small-W	Wandhalter, für senkrechte Montage DM2S – DM3S, weiss		C2	135.–
	Pan&Tilt Brkt Small-B	Dito, schwarz		C2	135.–
	WBPWR-50-W	Wandhalter für Aussenanwendung, DM5SE – DM6SE – DM8S – FS4SE, weiss		C2	325.–
	WBPWR-50-B	Dito, schwarz		C2	325.–
	DM2C Rough-In-Kit	Montageelement, DM2C-LP – FS2C (für Deckenkonstruktionen)		<u>C2</u>	145.– (6 Stück)
	DM3C Rough-In-Kit	Dito, DM3C		<u>C2</u>	145.– (6 Stück)
	DM5C Rough-In-Kit	Dito, DM5C – FS4CE		<u>C2</u>	145.– (6 Stück)
	DM6C Rough-In-Kit	Dito, DM6C		<u>C2</u>	145.– (6 Stück)
	DM8C Rough-In-Kit	Dito, DM8C		<u>C2</u>	145.– (6 Stück)



	FS2C Tile Bridge	Montageelement einstellbar, FS2C (für Deckenkonstruktionen)	<u>C2</u>	145.– (6 Stück)
	FS4C Tile Bridge	Dito, FS4C	<u>C2</u>	145.– (6 Stück)
	FS2CRFK-W	Adapterringen, FS2C, weiss	C2	105.– (Paar)
	FS2CRFK-B	Dito, schwarz	C2	105.– (Paar)
	FS4CERFK-W	Adapterringen, FS4CE, weiss	C2	105.– (Paar)
	FS4CERFK-B	Dito, schwarz	C2	105.– (Paar)
	FS4CE Grilles-W	Gitterabdeckung, FS4CE, Aluminium, weiss	<u>C2</u>	205.– (Paar)
	FS4CE Grilles-B	Dito, schwarz	<u>C2</u>	205.– (Paar)
	FS2SE Grilles-W	Gitterabdeckung, FS2SE, Aluminium, weiss	<u>C2</u>	145.– (Paar)
	FS2SE Grilles-B	Dito, schwarz	<u>C2</u>	145.– (Paar)
	FS4SE Grilles-W	Gitterabdeckung, FS4SE, Aluminium, weiss	<u>C2</u>	205.– (Paar)
	FS4SE Grilles-B	Dito, schwarz	<u>C2</u>	205.– (Paar)
	CMB S2-W	Deckenhalterung horizontal, FS2SE – FS4SE – DM3SE – DM5SE – DM6SE, weiss	<u>C2</u>	105.–
	CMB S2-B	Dito, schwarz	<u>C2</u>	105.–
	Threaded Rod	Gewindestangenadapter, DM3P – DM5P – DM6PE – DM10P-SUB	<u>C2</u>	30.– (Paar)
	Loudspeaker Conduit	Kabelschutzrohradapter, DM3P – DM5P – DM6PE – DM10P-SUB	<u>C2</u>	20.– (Paar)
	GEB-160T120	Einbetoniergehäuse mit Einbauöffnung 160mm, Höhe Innen 120mm, Höhe Aussen 125mm, Gewicht 450 Gr. <u>Passend zu:</u> BOSE DM2C, BOSE FS2C	C3	39.– *
	GEB-205T170	Einbetoniergehäuse mit Einbauöffnung 205mm, Höhe Innen 170mm, Höhe Aussen 185mm, Gewicht 1'250 Gr. <u>Passend zu:</u> BOSE DM3C	C3	75.– *
	GEB-250T170	Einbetoniergehäuse mit Einbauöffnung 250mm, Höhe Innen 170mm, Höhe Aussen 185mm, Gewicht 1'250 Gr. <u>Passend zu:</u> BOSE DM5C (Backbox demontieren), FS4CE	C3	75.– *
	GEB-295T160	Einbetoniergehäuse mit Einbauöffnung 295mm, Höhe Innen 160mm, Höhe Aussen 165mm, Ausführung in Metall <u>Passend zu:</u> BOSE DM6C (Backbox demontieren)	<u>C3</u>	215.– *



FreeSpace DS / Einbau-Lautsprecher				
	3 Flush mount Satellite-W	Full-Range, 2.25", 12W AES @6Ω, Frequenzbereich 210Hz-16kHz +/- 3dB, max. SPL 101dB, Aussen-Ø 157mm, Einbau-Ø 127mm, Einbautiefe 133mm, 0.9Kg, weiss	C2	265.– (Paar)
	3 Flush mount Satellite-B	Dito, schwarz	C2	265.– (Paar)
FreeSpace DS / Aufbau-Lautsprecher				
	360P-II 100V	Full-Range, 4.5", 10/20/40/80W@100V, Frequenzbereich 70Hz-15kHz +/- 3dB, max. SPL 100dB, 360° hor. / 50° vert, (360° horizontal, 50° vertikal, (H)380mm, Aussen-Ø 370mm, 6.5Kg, <u>Wetterfest</u> , grün	C2	575.–
	3S Satellite-W	Full-Range, 2.25", 12W AES @6Ω, Frequenzbereich 210Hz-16kHz +/- 3dB, max. SPL 101dB, (H)77mm x (B)77mm x (T)102mm, inkl. Wand- Deckenhalterung, 0.8Kg. weiss	C2	265.– (Paar)
	3S Satellite-B	Dito, schwarz	C2	265.– (Paar)
FreeSpace / Subwoofer				
	3S Bass-W	Subwoofer, 5.25", 100W AES @6Ω, 12/25/50/100/200W@100V, Frequenzbereich 50Hz-230Hz +/- 3dB, max. SPL 102dB, (H)356mm x (B)191mm x (T)342mm, 7.9Kg, inkl. Wand-Deckenhalterung, <u>max. 4 Satelliten</u> , weiss	C2	765.–
	3S Bass-B	Dito, schwarz	C2	675.–
	3 Flush mount Bass-W	Subwoofer, 5.25", 100W AES @6Ω, 12/25/50/100/200W@100V, Frequenzbereich 50Hz-230Hz +/- 3dB, max. SPL 102dB, Aussen-Ø 391mm, Einbau-Ø 362mm, Einbautiefe 190mm, <u>max. 4 Satelliten</u> weiss	C2	585.–
	3 Flush mount Bass-B	Dito, schwarz	C2	585.–
FreeSpace / Lautsprecher-Zubehör				
	GEB-120T120	Einbetoniergehäuse mit Einbauöffnung 120mm, Höhe Innen 120mm, Höhe Aussen 125mm, Gewicht 450 Gr. <u>Passend zu:</u> BOSE 3 Flush mount Satellit	C3	39.– *
	GEB-360T215	Einbetoniergehäuse zu 3 Flush mount Bass	C3	175.– *
	Rough-In-Pan Satellit	Montageelement, 3 Flush mount Satellite (abgehängte Deckenkonstruktionen)	C2	75.– (6 Stück)
	Rough-In-Pan Bass	Montageelement, 3 Flush mount Bass (Wand- und Deckenkonstruktionen)	C2	120.– (6 Stück)



EdgeMax / Einbau-Lautsprecher

	EM90	2-Weg, 8"/1.3", 150W AES 8Ω, 5/10/20/40/80@100V, Frequenzbereich 50Hz-18kHz -3dB, max. SPL 124dB, 90° hor. / 75° vert, (H)339 x (B)339 x (T)249 mm 10.1Kg, weiss , (Montage in Raumecke)	C2	885.–
	EM180	Dito, 180° hor. / 75° vert, (Montage in Raummitte)	C2	885.–
	EdgeMax Rough-In-Pan	Montageelement, EM90 - EM180	<u>C2</u>	75.– (Paar)
	EdgeMax Black Grille SNGL	Gitterabdeckung, schwarz	<u>C2</u>	75.–

Panaray / Aufbau-Lautsprecher

	MA12-W	Modular Säulen-Lautsprecher, 12x 2.5", 300W AES @8Ω, Frequenzbereich 155Hz-12kHz +/- 3dB, max. SPL 113dB, 145° hor. / 20° vert, (H)986mm x (B)107mm x (T)130mm, passiv, Pulverbeschichtet, 8.5Kg, weiss	C2	1'145.–
	MA12-B	Dito, schwarz	C2	1'145.–
	MA12EX-W	Modular Säulen-Lautsprecher, 12x 2.5", 150W AES @8Ω, Frequenzbereich 75Hz-13kHz +/- 3dB, max. SPL 109dB, 160° hor. / 20° vert, (H)986mm x (B)104mm x (T)140mm, passiv, <u>Wetterfest</u> , Pulverbeschichtet, 9.4Kg, weiss	C2	1'845.–
	MA12EX-B	Dito, schwarz	C2	1'885.–
	MSA12X-W	Modular Säulen-Lautsprecher, 12x 2.5", 600W, Frequenzbereich 75Hz-17kHz -3dB, max. SPL 112dB, 160° hor. / 30° vert, (H)984mm x (B)106mm x (T)206mm aktiv, DSP, Dante inkl. Wandhalterung, weiss	C2	4'395.–
	MSA12X-B	Dito, schwarz	C2	4'395.–

Panaray / Subwoofer

	MB210-WR-W	Subwoofer, 2x 10", 500W AES @8Ω, Frequenzbereich 45Hz-118Hz -3dB, max. SPL 112dB, Abstrahlwinkel omnidirektional (H)291mm x (B)685mm x (T)517mm, 27.2Kg, <u>Wetterfest</u> , inkl. Halterung, weiss	C2	1'075.–
	MB210-WR-B	Dito, schwarz	C2	1'075.–

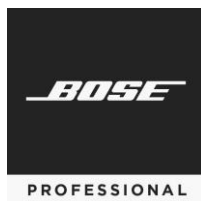

Panaray / Lautsprecher-Zubehör

	CVT-12 MA12-W	Transformator 100V, MA12, weiss	C2	280.–
	CVT-12 MA12-B	Dito, schwarz	C2	280.–
	CB-MA12 Coup. Bracket-W	Kupplungsstück, MA12, weiss	C2	85.–
	CB-MA12 Coup. Bracket-B	Dito, schwarz	C2	85.–
	CVT-12 MA12EX-W	Transformator 100V, MA12EX, weiss	C2	325.–
	CVT-12 MA12EX-B	Dito, schwarz	C2	325.–
	CB-MA12EX-W	Kupplungsstück, MA12EX, weiss	C2	75.–
	CB-MA12EX-B	Dito, schwarz	C2	75.–
	WMB BI-pivot Bracket-W	Universal Wandhalter, MA12 - MA12EX, neigbar 0-10°, schwenkbar +/- 90°, weiss	C2	165.–
	WMB BI-pivot Bracket-B	Dito, schwarz	C2	165.–
	WMB2 Upper Bracket-W	Wandhalter, Befestigung oben, MA12 - MA12EX, drehbar und neigbar, weiss	C2	105.–
	WMB2 Upper Bracket-B	Dito, schwarz	C2	105.–

AMM / Multipurpose Lautsprecher

	AMM108	2-Weg, 8"/1.7", 150W AES @8Ω, Frequenzbereich 88Hz-17kHz -3dB, max. SPL 116dB, 110° hor. / 60° vert, (H)318mm x (B)318mm x (T)268mm, 13Kg	<u>C2</u>	1'760.–
	AMM112	2-Weg, 12"/3", 300W AES @8Ω, Frequenzbereich 70Hz-18kHz -3dB, max. SPL 121dB, 110° hor. / 60° vert, (H)457mm x (B)457mm x (T)383mm, 22Kg	<u>C2</u>	2'970.–

AMM / Subwoofer

	AMS115	Subwoofer, 15", 500W AES @8Ω, Frequenzbereich 40Hz-100Hz - 3dB, max. SPL 90dB, Abstrahlwinkel omnidirektional, M10 Einsätze, Distanzstange, (H)475mm x (B)470mm x (T)508mm, 28Kg	C2	1'030.–
--	---------------	--	----	---------

AMM / Lautsprecher-Zubehör

	AMM108 U-Bracket	U-Bügel, AMM108	<u>C2</u>	205.–
	AMM112 U-Bracket	Dito, AMM112	<u>C2</u>	250.–
	AMM Suspension Bracket	Einpunktaufhängung, AMM108 – AMM112	<u>C2</u>	250.–







ShowMatch / Array-Lautsprecher

	SM5 DeltaQ	2-Weg, DeltaQ Array-Lautsprecher, LF: 2x 8" 600W AES @8Ω, HF: 4x 2" 125W AES @6Ω, Frequenzbereich 70Hz-16kHz +/- 3dB, max. SPL 128dB, 70° oder 100° hor. / 5° vert, (H)270mm x (B)793mm x (T)467mm 30.6Kg	<u>C2</u>	5'205.-
	SM10 DeltaQ	Dito, 70° oder 100° hor. / 10° vert, (H)282mm x (B)793mm x (T)465mm, 29.7Kg	<u>C2</u>	5'205.-
	SM20 DeltaQ	Dito, 70° oder 100° hor. / 20° vert, (H)303mm x (B)793mm x (T)461mm, 29Kg	<u>C2</u>	5'205.-
	SM5WG55	Waveguide für SM5, 55°	<u>C2</u>	165.- (Paar)
	SM20WG12	Waveguide für SM20, 120°	<u>C2</u>	165.- (Paar)

ShowMatch / Subwoofer

	SMS118 DeltaQ	DeltaQ Array-Subwoofer 18", 1250W AES @40Ω, Frequenzbereich 32Hz-250Hz +/- 3dB, max. SPL 137dB, Abstrahlwinkel omnidirektional, M10 Einsätze, Distanzstange, (H)540mm x (B)765mm x (T)775mm, 61.9Kg	<u>C2</u>	4'605.-
---	--------------------------	---	-----------	---------

ShowMatch / Array-Zubehör







	SMAF Array Frame	Flugrahmen für kompl. System inkl. SMS118 oder Ground Stack (Zwischen Array-Lautsprecher und Subwoofer muss ein zweiter SMAF eingesetzt werden)	<u>C2</u>	4'225.-
	SMAFT T-Bar Array Frame	Flugrahmen für die Verwendung ohne SMS118	<u>C2</u>	2'575.-
	SMQPS Short Quick Pin	Kurze Pin's für Festinstallationen ohne Seitenabdeckung	<u>C2</u>	190.- (4 Stück)
	SMGSB Ground Stack Bracket	Zubehör für Verwendung Ground Stack	<u>C2</u>	660.-
	SMPULL Pull- back Bracket	Flugrahmenerweiterung, weitere Einstellungsmöglichkeiten für die Neigung des Arrays	<u>C2</u>	1'030.-



ArenaMatch / Array-Lautsprecher





	AM6010	2-Weg, DeltaQ Array-Lautsprecher, LF: 14" 600W AES @8Ω, HF: 6x 2" 150W AES @8Ω, 200/4000@100V, Frequenzbereich 65Hz-16kHz +/- 3dB, max. SPL 135dB, 60° hor. / 10° vert, (H)408mm x (B)789mm x (T)473mm, <u>Wetterfest</u> , EN 54-24, 36Kg	<u>C2</u>	5'075.–
	AM8010	Dito, 80° hor. / 10° vert	<u>C2</u>	5'075.–
	AM10010	Dito, 100° hor. / 10° vert	<u>C2</u>	5'075.–
	AM6020	Dito, 60° hor. / 20° vert, (H)435mm x (B)789mm x (T)470mm, 36.2Kg	<u>C2</u>	5'075.–
	AM8020	Dito, 80° hor. / 20° vert	<u>C2</u>	5'075.–
	AM10020	Dito, 100° hor. / 20° vert	<u>C2</u>	5'075.–
	AM6040	Dito, 60° hor. / 40° vert, (H)484mm x (B)789mm x (T)454mm. 34.9Kg	<u>C2</u>	5'075.–
	AM8040	Dito, 80° hor. / 40° vert	<u>C2</u>	5'075.–
	AM10040	Dito, 100° hor. / 40° vert	<u>C2</u>	5'075.–

ArenaMatch / Array-Zubehör

	AMWG1060	Waveguide 60° für AM10	<u>C2</u>	175.– (Paar)
	AMWG1080	Dito, 80°	<u>C2</u>	175.– (Paar)
	AMWG1010	Dito, 100°	<u>C2</u>	175.– (Paar)
	AMWG2060	Waveguide 60° für AM20	<u>C2</u>	175.– (Paar)
	AMWG2080	Dito, 80°	<u>C2</u>	175.– (Paar)
	AMWG2010	Dito, 100°	<u>C2</u>	175.– (Paar)
	AMWG4060	Waveguide 60° für AM40	<u>C2</u>	175.– (Paar)
	AMWG4080	Dito, 80°	<u>C2</u>	175.– (Paar)
	AMWG4010	Dito, 100°	<u>C2</u>	175.– (Paar)
	AMAPLONG	Deckenhalterung lang	<u>C2</u>	635.– (Paar)
	AMAPSHRT	Deckenhalterung kurz	<u>C2</u>	395.– (Paar)
	AMAPSPRD	Halterung zwischen AMAPLONG oder AMAPSHRT	<u>C2</u>	485.–
	AMMCPLAT	Verbindungsplatte zwischen 2 Array-Module	<u>C2</u>	240.– (Paar)
	AMPULL	Universalhalterung	<u>C2</u>	395.– (Paar)
	AMUBRKT	U-Bügelhalterung	<u>C2</u>	325.–











ArenaMatch Utility / Aufbau-Lautsprecher

	AMU105-W	2-Weg, 5.25"/2", 150W AES @8Ω, 10/20/40/80W@100V, Frequenzbereich 100Hz-18kHz -3dB, max. SPL 119dB, 100° hor. / 100° vert, (H)152mm x (B)332mm x (T)246mm, inkl. U-Bügel, <u>Wetterfest</u> , EN 54-24, 6.5Kg, weiss	<u>C2</u>	750.-
	AMU105-B	Dito, schwarz	<u>C2</u>	750.-
	AMU108-W	2-Weg, 8"/2", 250W AES @8Ω, 10/20/40/80W@100V, Frequenzbereich 90Hz-16kHz -3dB, max. SPL 123dB, 90° hor. / 60° vert, (H)235mm x (B)498mm x (T)316mm, inkl. U-Bügel, <u>Wetterfest</u> , EN 54-24, 10.6Kg weiss	<u>C2</u>	1'165.-
	AMU108-B	Dito, schwarz	<u>C2</u>	1'165.-
	AMU206-W	2-Weg, 2x 6.5"/2", 300W AES @8Ω, 10/20/40/80W@100V, Frequenzbereich 90Hz-16kHz -3dB, max. SPL 124dB, 120° hor. / 60° vert, (H)205mm x (B)552mm x (T)241mm, inkl. U-Bügel, <u>Wetterfest</u> , EN 54-24, 12.2Kg weiss	<u>C2</u>	1'335.-
	AMU206-B	Dito, schwarz	<u>C2</u>	1'335.-
	AMU208-W	2-Weg, 2x 8"/2", 400W AES @8Ω, 10/20/40/80W@100V, Frequenzbereich 80Hz-16kHz -3dB, max. SPL 129dB, 90° hor. / 60° vert, (H)236mm x (B)686mm x (T)267mm, inkl. U-Bügel, <u>Wetterfest</u> , EN 54-24, 17Kg weiss	<u>C2</u>	1'425.-
	AMU208-B	Dito, schwarz	<u>C2</u>	1'425.-
ArenaMatch Utility / Lautsprecher-Zubehör AMU105 - 108 - 206 - 208				
	WBPWR-50-W	Wandhalter für Aussenanwendung, AMU105 - 108 - 206 - 208	<u>C2</u>	325.-
	WBPWR-50-B	Dito, schwarz	<u>C2</u>	325.-







Fernbedienungen

FreeSpace, PowerShare, ControlSpace, PowerMatch

	ControlCenter CC-1-W	Analoger Lautstärkereger, weiss , IZA – PS – ESP – EX	C2	105.–
	ControlCenter CC-1-B	Dito, schwarz	C2	105.–
	ControlCenter CC-1D-W	Digitaler Lautstärkereger, PoE, weiss , CSP – ESP – EX – PowerMatch	C2	215.–
	ControlCenter CC-1D-B	Dito, schwarz	C2	225.–
	ControlCenter CC-2-W	Analoger Lautstärkereger, Quellenauswahl (A/B), weiss , IZA – ESP – EX	C2	120.–
	ControlCenter CC-2-B	Dito, schwarz	C2	120.–
	ControlCenter CC-2D-W	Digitaler Lautstärkereger, Quellenauswahl (A/B), PoE, weiss , CSP – ESP – EX – PowerMatch	C2	265.–
	ControlCenter CC-2D-B	Dito, schwarz	C2	265.–
	ControlCenter CC-3-W	Analoger Lautstärkereger, Quellenauswahl (A/B/C/D), weiss , ESP – EX	C2	120.–
	ControlCenter CC-3-B	Dito, schwarz	C2	120.–
	ControlCenter CC-3D-W	Digitaler Lautstärkereger, Quellenauswahl (A/B/C/D), PoE, weiss , CSP – ESP – EX – PowerMatch	C2	310.–
	ControlCenter CC-3D-B	Dito, schwarz	C2	310.–
	CV41 4 to 1 Converter	Verteiler, für PowerShare Verstärker (max.4x CC-1 EU)	C2	145.–
	ControlSpace CC-64	Wandpanel, LCD-Display 2x40 Zeichen, 4 Endlos-Drehregler mit Taster, 1 Regler für Parameterkombinationen, Spannungsversorgung lokal oder via Netzkabel, weiss ControlSpace, PowerMatch mit Network	C2	1'225.–
	ControlSpace CC-16	Wandpanel, 2-Zeilig, Quellen/Presetwahl, Lautstärkeregelung, Spannungsversorgung lokal oder via Netzkabel, weiss ControlSpace	C2	395.–



ControlSpace / Fernbedienungen-Zubehör

	CC-PS 1 Power Supply	Netzteil für lokale Spannungsversorgung, CC-64 – CC-16	C2	75.–
	Surface Box CC-64	AP-Rahmen, CC-64, weiss	C2	125.–
	Surface Box CC-16	AP-Rahmen, CC-16, weiss	C2	125.–
	Flush Mount Box CC-64	UP-Box, CC-64	C2	45.–
	Flush Mount Box CC-16	UP-Box, CC-16	C2	45.–



Verstärker

FreeSpace / Mischverstärker				
	IZA 2120 HZ	Mischverstärker, 2x 120W@100V, 2x Line-In, 1x Paging-In, 2 Zonen, 2x RCA-Out, 19", 1HE	C2	1'205.–
	IZA 2120 LZ	Mischverstärker, 2x 120W@4Ω, 2x 60W@8Ω, 2x Line-In, 1x Paging-In, 2x RCA-Out, 19", 1HE	C2	1'075.–
	IZA 190 HZ	Mischverstärker, 1x 90W@100V, 1x Mic/Line-In, Aux-In, 1x Paging-In, 1 Zonen, 2x RCA-Out, ½-19", 1HE	C2	635.–
	IZA 250 LZ	Mischverstärker, 2x 50W@4Ω, 2x 25W@8Ω, 1x Mic/Line-In, Aux-In, 1x Paging-In, 2 Zonen, 2x RCA-Out, ½-19", 1HE	C2	530.–
FreeSpace / Verstärker-Zubehör				
	IZA/ZA Rack mount Kit	Rackwinkel für IZA – ZA, ½-19" Versionen (für einen einzelnen oder zwei Verstärker)	C2	45.–
PowerShare				
	PS404D	4-Kanal Verstärker, Gesamtleistung 400W@4-8Ω/100V, DSP, 19", 1HE, 6.4Kg, Dante (Leistung flexibel verteilbar)	C2	2'295.–
	PS604D	4-Kanal Verstärker, Gesamtleistung 600W@4-8Ω/100V, DSP, 19", 1HE, 6.4Kg, Dante (Leistung flexibel verteilbar)	C2	2'825.–
PowerSpace				
	P2600A	2-Kanal Verstärker, 2x 600W@4Ω/8Ω/100V, I-Share Mode 1x 1200W@2Ω/4Ω/100V, 19", 1HE, inkl. Amp-Link	C2	1'340.–
	P21000A	Dito, 2x 1000W@4Ω/8Ω/100V, I-Share Mode 1x 2000W@2Ω/4Ω/100V	C2	1'750.–
	P4150+	4-Kanal Verstärker, 4x 150W@4Ω/8Ω/100V I-Share Mode 2x 300W@2Ω/4Ω/100V, DSP, 19", 1HE,	C2	2'145.–
	P4300+	Dito, 4x 300W@4Ω/8Ω/100V, I-Share Mode 2x 600W@2Ω/4Ω/100V	C2	2'425.–
	P4300A	Dito, inkl. Amp-Link (ohne DSP)	C2	1'885.–
PowerMatch				
	PM4500N Network	4-Kanal Verstärker, Gesamtleistung 2000W, I-Share Mode 4x 500W@4Ω, V-Bridge Mode 2x 1000W@4Ω /100V, I/O Digital Card Slot, DSP, 19", 2HE, 13.6Kg	C2	3'605.–
	PM8500N Network	8-Kanal Verstärker, Gesamtleistung 4000W, I-Share Mode 8x 500W@4Ω, V-Bridge Mode 4x 1000W@4Ω /100V, I/O Digital Card Slot, DSP, 19", 2HE, 15.7Kg	C2	4'995.–
	PM8250N Network	8-Kanal Verstärker, Gesamtleistung 2000W, I-Share Mode 8x 250W@4Ω, V-Bridge Mode 4x 500W@4Ω /100V, I/O Digital Card Slot, DSP, 19", 2HE, 15.4Kg	C2	3'045.–
PowerMatch / Verstärker-Zubehör				
	Dante Network Card	Dante Netzwerkkarte, 8-In/8-Out	C2	795.–
	Amplink Card	Schnittstellenkarte zwischen EX-DSP und PowerMatch Endstufe	C2	295.–



DSP



Commercial Sound Processor

	CSP-428	4-In/2-Out Signal-Processor, Amp-Link, Control-In, Logic-Out, 19", 1HE, Programmierung via Webbrowser	C2	1'205.–
	CSP-1248	12-In/4-Out Signal-Processor, Amp-Link, Control-In, Logic-Out, 19", 1HE, Programmierung via Webbrowser	C2	2'015.–

Commercial Sound Processor / Zubehör

	AVM-1	Deckenmikrofon für automatische Lautstärken-Kompensation	C2	220.–
---	--------------	--	----	-------

ControlSpace

	EX-1280	12-In/8-Out Signal-Processor, 64x64 Dante, USB, RS232, Amp-Link, Control-In, Logic-Out, 19", 1HE	C2	3'915.–
	EX-1280C	Dito, AEC, VoIP	C2	4'455.–
	EX-440C	4-In/4-Out Signal-Processor, 16x16 Dante, AEC, VoIP, USB, RS232, Amp-Link, Control-In, Logic-Out, 19", 1HE	C2	3'365.–
	EX-12AEC	AEC Signal-Processor, 16x16 Dante, 19", 1HE	C2	2'280.–
	ESP-880A	8-In/8-Out Signal-Processor, Amp-Link, Control-In, Logic-Out, RS232, 19", 1HE	C2	2'560.–

DSP Erweiterungen

ControlSpace / Dante-Erweiterungen

	EX-8ML	Dante Schnittstelle, 8-Mic/Line Eingänge, 48V, Logic In/Out, PoE oder 12VDC	C2	2'015.–
	EX-4ML	Dante Schnittstelle, 4-Mic/Line Eingänge, 48V, Logic In/Out, PoE oder 12VDC	C2	1'145.–
	EX-UH	Dante Schnittstelle, USB, Telefon-Headset (RJ9 u. TRRS), PoE oder 12VDC	C2	915.–

Zubehör Erweiterungen

	EX-UTB	Montagehalterung (magnetisch), EX-8ML - EX-4ML - EX-UH	C2	105.–
---	---------------	--	----	-------

* GoWild (kein BOSE) Artikel